

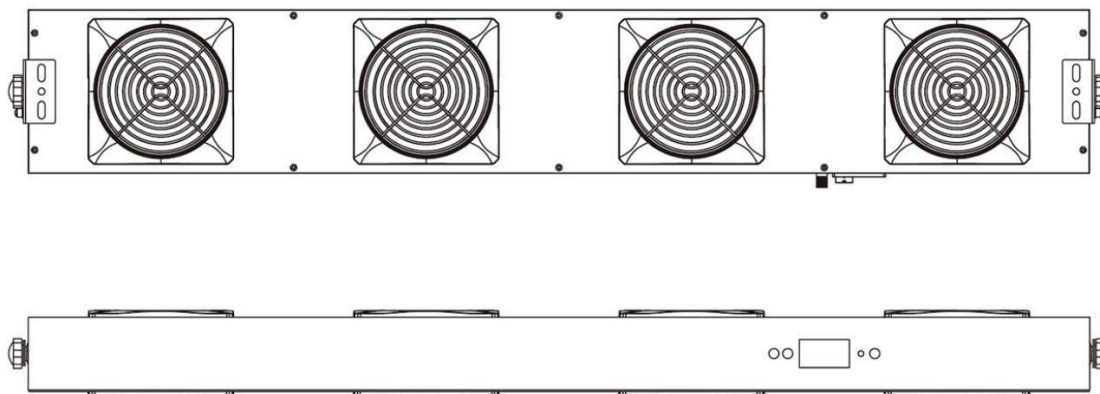

BFN-714S-L

# Four-Head DC Ion Fan

User Manual



# SHENZHEN HORB TECHNOLOGY CORP. LTD.

📍 Address: Block B, Funing Hi-tech Innovation Park, No.71-2 Xintian Rd.,  
Fuyong Town, Bao'an District, Shenzhen, China.

☎ Service Hotline

0755-29461997 / 13923798431

🌐 [www.horb.com.cn](http://www.horb.com.cn)



Official Website



Official WeChat Account

## Company Profile

Shenzhen HORB Technology Corp.Ltd. (Hereinafter Referred To As "HORB") Was Established In 2001 , Headquarter Located In Baoan District Of Shenzhen City, Listed On The National Stock Transfer System(Stock Code: 870762),It Has Been Approved As A National High-Tech Enterprise, A Specialized And Special New Enterprise In Guangdong Province, A "Contract-Abiding And Credit-Worthy" Enterprise In Guangdong Province, The Sixth Innovation Top 100 Enterprise Of Shenzhen City, Post-Doctoral Innovation Practice Base, Shenzhen Vocational And Technical College Practice Base... HORB Is The Vice Director Of Shenzhen Clean Industry System Solution (The Chairman Unit Of The Anti-Static Professional Committee), The Vice President Of Shanghai ESD Association, The Member Of Anti-Static Equipment Of China Electronic Instruments Industry Association, And The Member Of ESD Association Of The United States.

HORB Technology Has Long Been Committed To The Research And Development And Service Of "Controlled Environment Intelligent System Solutions", Based On Clean Control Technology, Electrostatic Protection Technology, Vision And Information Technology. Provide P+1 Smart Clean Space Engineering, P02 Clean Cloud Smart Control Platform, P03 Smart VMI Consumables Integration, +1 Solution Integrating Consulting And Training. Customers Are Mainly Concentrated In High-End Electronics Manufacturing, Biomedicine, Military Industrial Institutes, And Government And Enterprise Units.

We Have Applied For And Approved More Than 30 Invention Patents, More Than 30 Utility Model Patents, 3 PCT International Patent, More Than 10 Software Copyrights, More Than 30 Domestic Trademarks, 4 Madrid Trademarks, About 30 Products CE Certified, National Industrial Production Permit, ISO9001, ISO14001,OHSAS18001, ISO13485 System Certification, LA Certification, Domestic Second-Class Medical Device Certification, Multi-Country Medical Device Product Certification And System Certification. Participation In The Preparation Of 6 National Standards, 1 Industry Standard, 3 Group Standard.

HORB People Do Not Forget The Original Ideals And Aspirations, Always Adhere To Provide Customers With High-Quality Products And Services. Best Resource, Owned By HORB, Is The First Professional Organization In China To Focus On The Research And Promotion Of ESD Protection Technology And Clean Technology, Shenzhen Higher Vocational College's Contracted Industry-University-Research Cooperation Unit, Clean Engineering Professional Teaching Agent, INARTE Authorized China Regional Examination Center Of ESD Engineers Of United States, Senior Consultant Of Multiple Institutions And Enterprises. As Of The End Of 2022, Serving More Than 5,000 Enterprises And Training Professional Talents With More Than 40,000 Person-Times And Efforts To Be Made To Provide The Country With More Professional And Technical Personnel In The Industry.

HORB Is Adhering To The "Being Customer –Focused, Credibility And Openness, Profession And Diligence, Co-Creation And Sharing" Values, To Achieve "To Make Every Enterprise & Family More Safe And Cleaner, To Make Every Customer More Moved, To Make Every Employee More Happier, To Make Every Partner More Satisfied" Corporation Mission, Constantly Improve The Competitiveness Of Enterprises, Has Been Set Up Own Brands: HORB, Clean Cloud, BFN, ECO, KANBO, Yijielianghang, BEST-RESOURCE, Sijiali, Howay,Gradually Formed A Stronger Core Technology And Brand Advantages, Set Up Domestic Offices In Beijing, Yantai, Qingdao, Suzhou, Chongqing, And Chengdu, And Set Up Overseas Subsidiaries In Hong Kong, Thailand, Vietnam, The Philippines, India, And Germany. And With Many Domestic And Foreign Brand Enterprises, Such As: Huawei, OPPO, BOE, Foxconn, Flextronics, Samsung, WD, Seagate, Sony, Military Institutes, Government And Enterprise Units Have Established Long-Term Cooperative Relations.

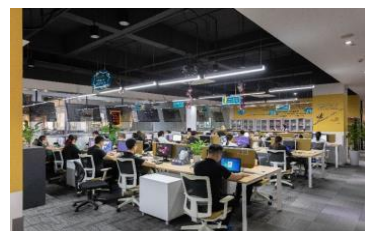

## Contents

1. Product Features .....	- 1 -
2. Industry Applications.....	- 3 -
3. Performance Parameters.....	- 3 -
4. Structural Parameters and Certification.....	- 4 -
5. Operating Mode (Pulsed DC).....	- 4 -
6. Static Elimination Effect .....	- 5 -
7. Operation and Installation .....	- 6 -
8. Online Connection Schematic.....	- 11 -
9. Maintenance .....	- 11 -
10. After-Sales Service .....	- 12 -
11. Packaging Accessories .....	- 12 -

# 1. Product Features



- ◆ Equipped with tactile switch buttons for convenient and quick operation.
- ◆ Multiple air outlets, each with 8 emitter pins, ensuring high ion output.
- ◆ Automatic emitter pin cleaning at startup, and subsequently every 4 hours by default, eliminating manual cleaning maintenance.
- ◆ High-volume fans with five adjustable speed settings; output airflow is 1.45 times higher than ordinary fans, ensuring stable performance.
- ◆ Features an LCD display showing device address (e.g., A00), fan speed level (e.g., S1), cleaning cycle (e.g., T04), temperature/humidity, cleaning prompt (Cleaning...), fan fault alarm (Fan Fault!!!), high voltage fault alarm (HV Fault!!!). Real-time display of balance voltage for each outlet; alarm if exceeds set threshold (Ion Fault!!!). Alarm triggered when high voltage output is 0V.
- ◆ Features self-balancing ion technology with a range of  $\pm 10V$ , and real-time display of balance voltage.
- ◆ Negative high voltage amplitude can be remotely adjusted via remote control for fine-tuning ion balance voltage.

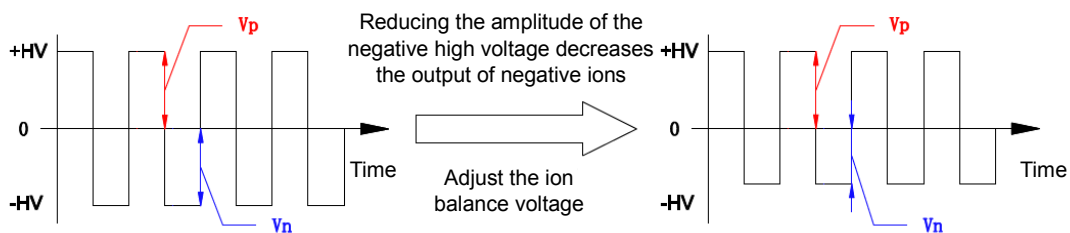

- ◆ Display outputs fault alarms and LED emits red light for fan, ion balance, and high voltage faults.
- ◆ Ion output characteristics can be adjusted using the remote control.
- ◆ Supports wired network communication for monitoring blower operating status.

LCD Display Parameter Description		
Display Mark	Mark Description	Illustration
RUN/STOP	Operation/Pause Display	
A00	Displays the current device working address: 00	Green light: Operation state
S4	Displays the current fan speed gear: 4	
T04	Displays the current device cleaning cycle: 04 (Unit: hour)	Blue light: Pause/Standby state
F2 F1	Displays the current device air outlets (AP-DJ28 series ion fans have 1 to 4 air outlets)	
+07 -08	Displays the balance voltage of the corresponding air outlet	Blue light flashing: Cleaning
28°C	Displays the ambient temperature of the current device working environment	
62%RH	Displays the ambient humidity of the current device working environment	Red light: Fan fault alarm
Cleaning	Current device cleaning prompt	
Fan Fault	Current device fan fault alarm	Red light flashing: High-voltage alarm
HV Warning	Current device high-voltage fault alarm	

- ◆ Magnetically attached front grille; power is immediately cut off when the grille is removed, putting the blower into standby (STOP) mode for safe and convenient cleaning.
- ◆ Passed CE testing, features electromagnetic protection, preventing electromagnetic interference to other equipment and effectively shielding against external electromagnetic interference affecting normal blower operation.

## 2. Industry Applications

- ◆ Widely applicable to electronics, semiconductor, optoelectronics and other industries.

## 3. Performance Parameters

Input Voltage	DC 24V (RJ45 interface) / 3-in-1 socket (220VAC 50/60Hz)
Power	42.5W
Output Voltage	DC $\pm 4\text{KV} \rightarrow \pm 6\text{KV}$
Ion Emission	Pulsed DC
Emitter Electrode	Tungsten
Static Elimination Range	750*1050mm (LW)
Airflow	$\leq 135 \text{ CFM} * 4$
Audible Noise	Single outlet $\leq 58 \text{ dBA}$ (measured 1000mm from outlet)
Ozone Concentration	$\leq 0.05 \text{ ppm}$ (measured 150mm from outlet)
Ion Balance	$\leq  \pm 15\text{V} $
Discharge Time	$\leq 2.5\text{S}$ (measured 450mm directly below outlet)
Status Indication	Startup/Momentary, Cleaning Running -> Blue light flashing; Normal Operation -> Green light (constant monitoring); Fan Fault Alarm -> Red light steady ON; Balance Voltage Exceedance Alarm -> Red light flashing; High Voltage Fault Alarm -> Red light flashing.
Communication Method	RS485
Signal Output	RS485 (115200bps, 8, 1, n, n) $\geq 20\text{ms}$ ; Open Collector: $< 50\text{V}$ , 100mA
Compatible Power Adapter	Plug-in power supply: INPUT: AC100-240V 50/60Hz; OUTPUT: DC24V 2A (Dual RJ45 interface)

## 4. Structural Parameters and Certification

Dimensions	1037 * 154 * 192 mm (LWH)
Housing Material	Aluminum, powder-coated
Net Weight (blower body & mounting bracket only)	4.85 KG
Installation Accessories	1 pair L-shaped aluminum powder-coated mounting brackets, 1 pair Bakelite screw knobs (M5×8)
Certification	CE
Warranty	1 Year
Operating Environment	Indoor use, Temperature: 0°C - 50°C, Relative Humidity: < 70% RH
Dimensions	1037 * 154 * 192 mm (LWH)
Housing Material	Aluminum, powder-coated

## 5. Operating Mode (Pulsed DC)

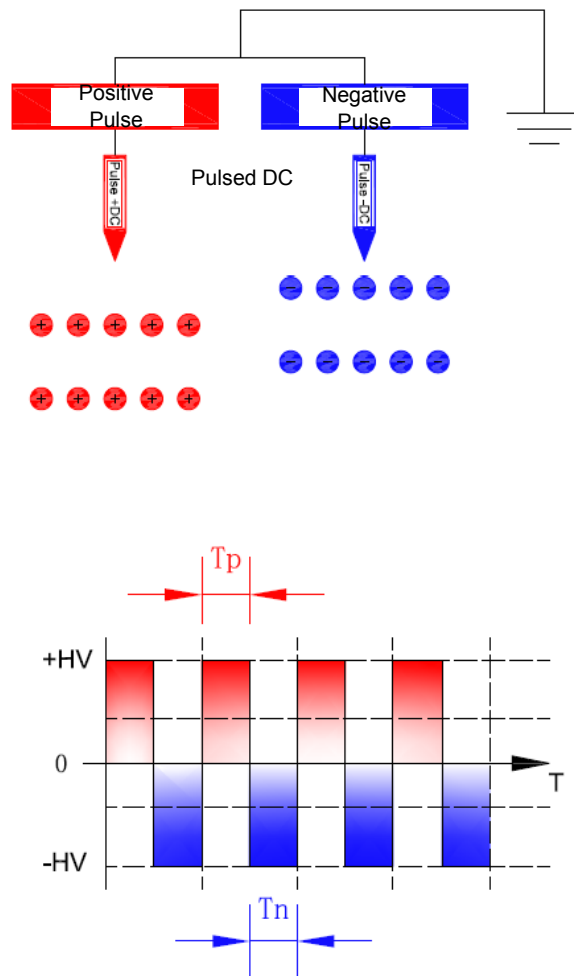

## 6. Static Elimination Effect

- ◆ Test Standard: ANSI/ESD.STM3.1, SJ/T 11446-2013
- ◆ Test Instrument: Trek Charge Plate Monitor
- ◆ Test Voltage:  $\pm 1000V \rightarrow \pm 100V$  Attenuation
- ◆ Test Environment: Humidity  $50 \pm 5\%$ ; Temperature  $23 \pm 3^\circ C$
- ◆ Test Position Schematic:

Note: The 0-point position of the test length is the center position of the fan.

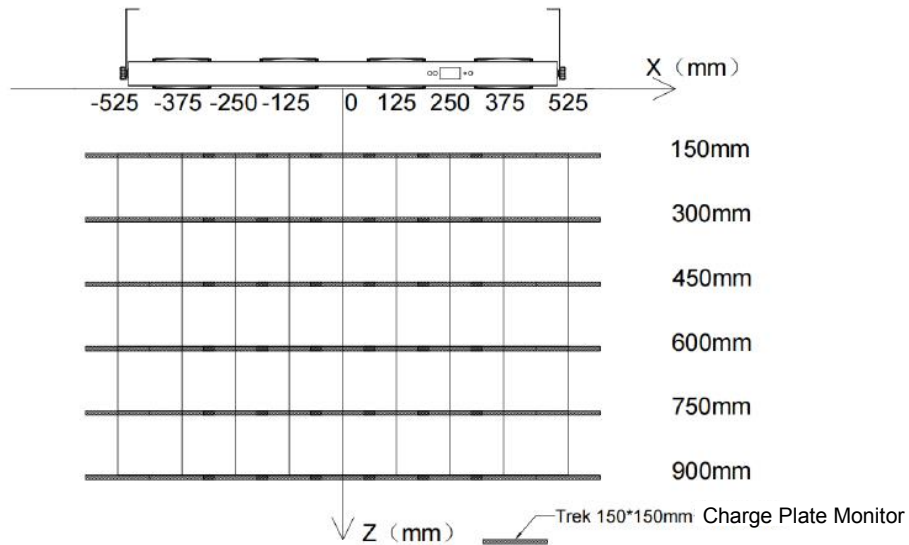

- ◆ Static Elimination Effect Schematic:

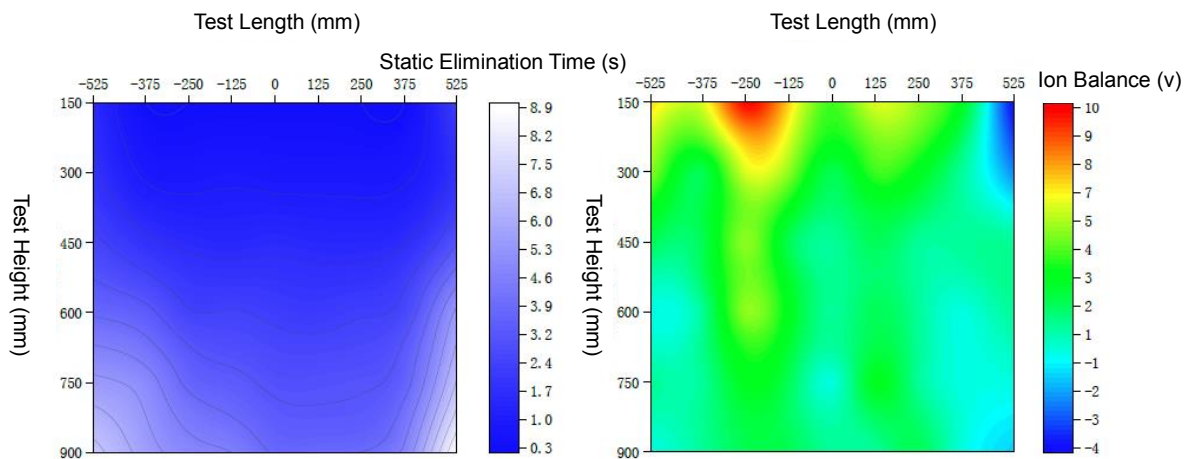

# 7. Operation and Installation

◆ Installation and Operation Guide

- a) Select the optimal static elimination position and firmly install the fan and the matching adapted power supply.
- b) Insert the network cable connected to the adapted power supply into the RJ45 power socket of the ion fan, and insert the power plug of the adapted power supply into the AC power strip.
- c) Hanging type (multi-head) fans can also be directly powered by 220VAC; when both 220VAC and 24VDC are connected to the fan, the actual power supply is 220VAC.
- d) Touch the power switch on the front panel of the ion fan; the ion fan will automatically brush the needles after startup, and the fan works normally when the indicator light is green.

◆ External Dimensions Diagram:

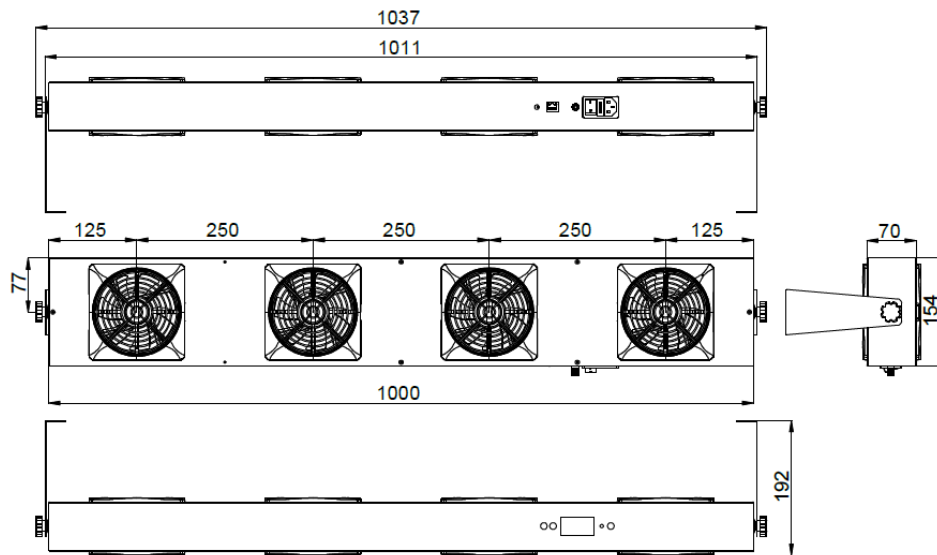

External Dimensions Diagram

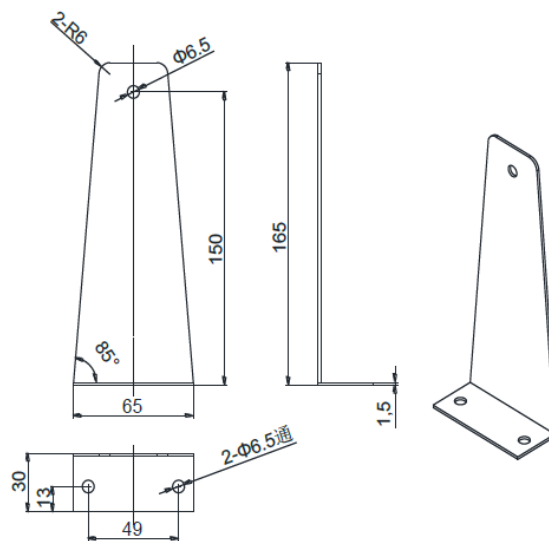

Mounting Bracket External Dimensions Diagram

◆ Front and Rear Panel Illustration and Power Interface Cable Information:

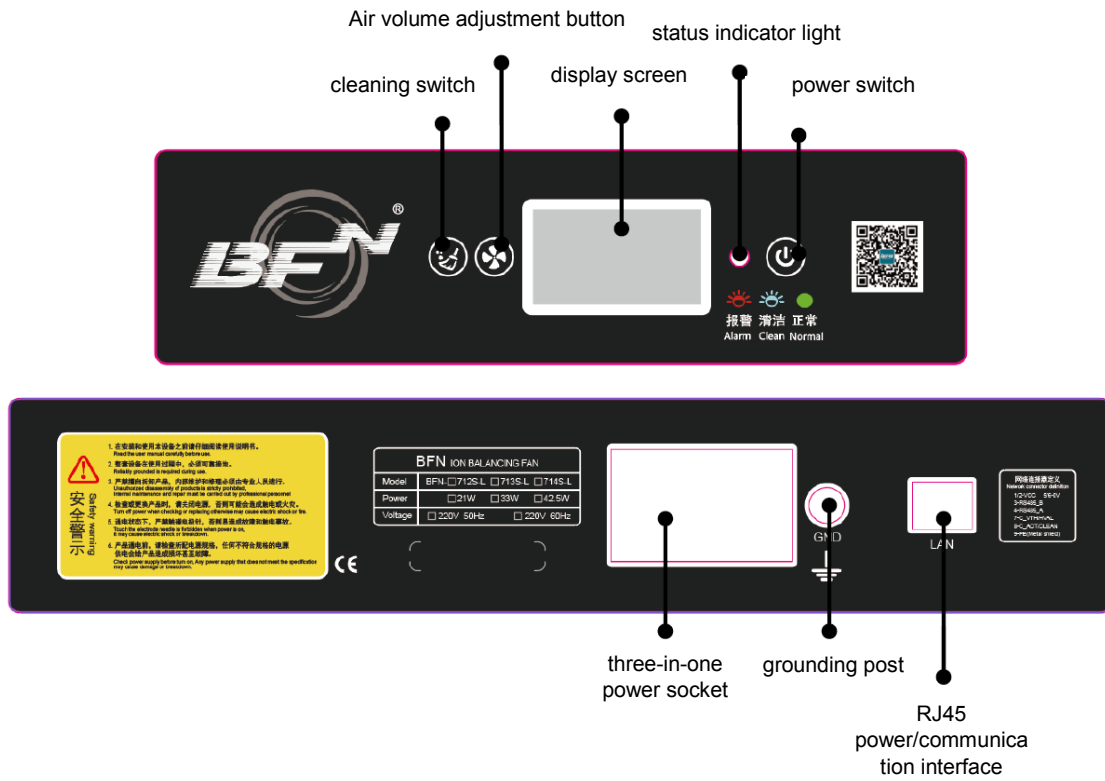

Power Interface Wiring Function Information		
1,2	Orange, White-Orange	VCC: +24VDC
3	Blue	RS485+B
4	White-Blue	RS485+A
5,6	Green, White-Green	GND
7	Brown	V TH: Sensor threshold alarm; HV AL: Static eliminator high-voltage alarm
8	White-Brown	ACT: Sensor/static eliminator power-on indication; Clean: Static eliminator cleaning indication
9	Metal shield	PE

Output wiring diagram for pins 7 and 8 (as follows):

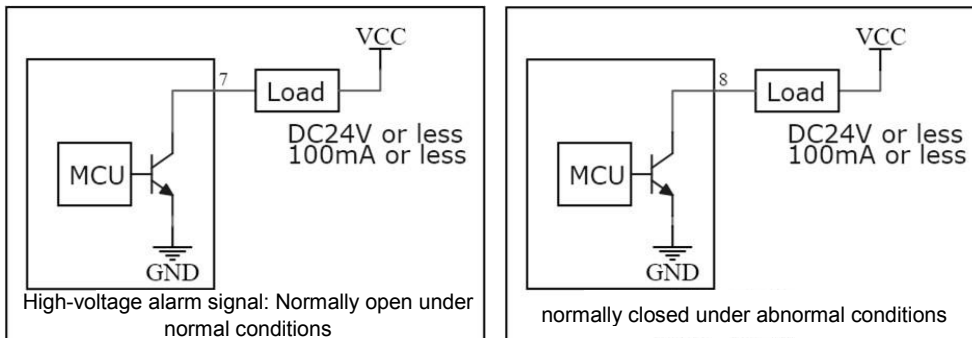

◆ Remote Control Instructions:



Key Function	Symbol	Operation Instructions
Unlock		Must unlock before adjusting operating parameters. After any key press, operation extends for 30 seconds; if no key is pressed for 30 seconds, it exits and locks.
Run/Pause		Device is in running state after power-on. Press Pause key to put device in standby (STOP), no high voltage output. Press Run key again to start operation.
Clean		Press this key to perform one emitter pin cleaning cycle.
Adjust Cleaning Cycle	CT <sub>TH</sub> → +/-	First press CT <sub>TH</sub> , then press +/- to increase or decrease the cleaning cycle. Minimum adjustment unit is 1H.
Fan Speed Adjustment	CFM → +/-	First press CFM, then press +/- to adjust fan speed from high to low in order: Gear 1, Gear 2, Gear 3, Gear 4, Gear 5.
Adjust Ion Balance	IB <sub>N</sub> → +/-	First press IB <sub>H</sub> , then press +/- to adjust the ion balance voltage.
Confirm	CAL → OK	Note: After adjusting output parameters, you must first press CAL, then press OK to confirm; otherwise, false alarms may easily occur.
Reset	CAL →	Restore factory settings (150Hz, 50%, 4H): First press CAL, then press

When the charged plate monitor or object surface shows a high positive voltage, first press IB<sub>N</sub>, then press +. When it shows a high negative voltage, first press IB<sub>N</sub>, then press -. Adjust until the balance voltage reaches the ideal state.

◆ Technical Tips:

- a) When using the ionizing blower, place it within the work area where static elimination is required. The installation angle should be perpendicular to the charged surface.
- b) The ionizing blower should be kept at least 30cm away from metal conductors and grounded metal objects. The blower must be reliably connected to the grounding wire.
- c) When installing two ionizing blowers side-by-side, maintain an interval of at least 40cm. Maintain a distance of at least 20cm from obstacles like walls.

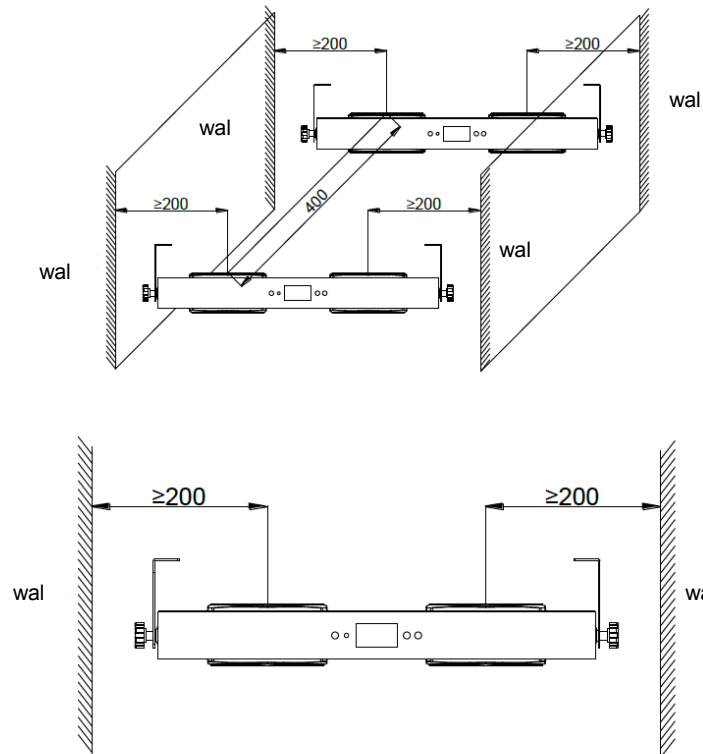

- d) The air intake should ideally be at least 150mm away from walls.

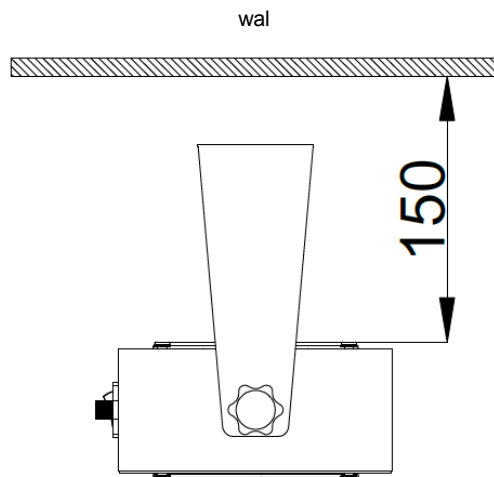

e) Troubleshooting Guide:

No.	Problem	Possible Cause	Solution
1	Blower panel indicator light does not turn on.	Poor power cable connection.	Verify power cable is intact and securely connected.
		Incorrect power supply matching.	Confirm power supply specifications (INPUT: 100-240VAC 50/60Hz; OUTPUT: 24VDC 2000mA).
2	Significantly reduced static elimination performance.	Discharge needles contaminated or damaged.	Clean or replace discharge needles.
		Incorrect positioning of ionizing blower.	Confirm optimal installation position.
		Cleaning brush blocking electrode pins.	Use remote control to manually clean pins, or restart the blower to move the cleaning brush away from electrode pins.
3	Reduced static elimination performance.	Conductors or other ionizing blowers nearby.	Remove or relocate conductors or other ionizing blowers.
4	High voltage / Ion balance alarm occurs (Panel indicator light flashes red).	Electromagnetic interference.	Turn off power switch / unplug power cord, restart the device.
		Abnormal discharge.	Check if electrode pins are close to or touching metal objects; remove foreign objects.
		High voltage module no power supply, High voltage module damaged.	Return to factory for repair.
		Ion balance alarm.	Clean electrodes and grille, then re-adjust using remote control.
		Cleaning brush blocking electrode pins.	Use remote control to manually clean pins, or restart the blower to move the cleaning brush away from electrode pins.
5	Fan alarm occurs (Panel indicator light red steady ON).	Fan malfunction.	Return to factory for repair.
		Fan power supply/control circuit damaged.	Return to factory for repair.
6	Cannot eliminate static.	High voltage module damaged, mainboard chip damaged.	Return to factory for repair.
		Poor grounding/No grounding/Incorrect power supply circuit causing chip damage.	Check grounding of ionizing blower and facility equipment; return to factory for repair.
7	Display screen off or distorted.	Abnormal discharge, high voltage module failure.	Return to factory for repair.
		Poor grounding or incorrect product power supply circuit.	Check grounding of ionizing blower and facility equipment; return to factory for repair.
8	Product smokes or burns.	High voltage module damaged or discharge bracket insulation damaged.	Return to factory for repair.

## 8. Online Connection Schematic

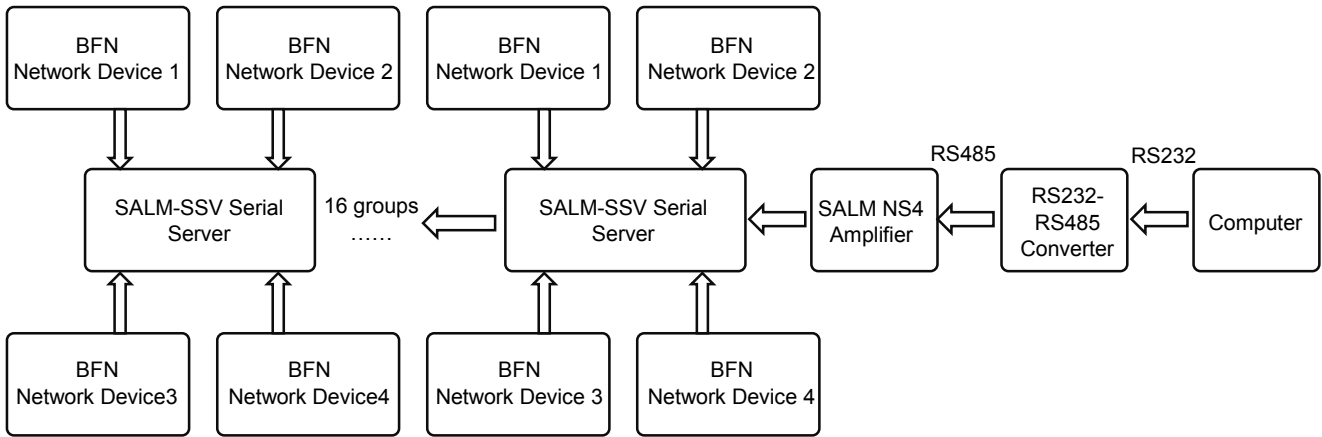

## 9. Maintenance

- ◆ To ensure optimal product performance, clean and maintain the blower promptly according to the usage environment and required electrostatic protection level. Use a static-dissipative brush, lint-free swab, or lint-free cloth slightly dampened with anhydrous alcohol to gently remove dust from the discharge electrodes, discharge bracket, fan, and metal grille.

### Note:

- a) Must operate after cutting off power for 10 minutes.
  - b) During use, set the electrode pin cleaning cycle based on the operating environment; the more humid or dusty the environment, the shorter the cleaning cycle should be.
  - c) After cleaning, wait for the alcohol to completely evaporate before powering on again. Do not use any other organic solvents to clean the blower.
  - d) Discharge electrodes are consumable items and are not covered by the warranty. The company will charge for replacement during repairs.
- ◆ Users must not excessively press or rotate the control buttons/knobs on the blower panel, as this will cause permanent damage to the components.
  - ◆ If the operation indicator light on the front panel goes out or shows a red alarm, stop using the blower immediately. It must be inspected and repaired by professional maintenance personnel. Only resume use after verifying that the electrical performance parameters are normal.

## 10. After-Sales Service

- ◆ The BFN-714S-L DC ion fan has undergone rigorous testing, inspection and aging treatment before leaving the factory, and its performance fully meets the relevant indicators marked in the user manual.
- ◆ Horb Technology makes the following commitments to users: Within one year from the date of purchase, the company will repair or replace any defective parts inspected by the company free of charge. However, this commitment does not apply to the following situations:
  - a) Misuse or improper installation of the equipment;
  - b) Damage caused by negligence or accident during use;
  - c) Self-modification, disassembly or repair by non-authorized service departments other than Horb Technology.
- ◆ Except for the repair or replacement of parts within the scope of this regulation, Horb Technology shall not bear any other obligations or related liabilities to product users.

## 11. Packaging Accessories

- ◆ Warranty Card × 1
- ◆ Instruction Manual × 1
- ◆ Power Adapter × 1
- ◆ Standard Power Cord × 1
- ◆ Remote Control × 1
- ◆ Power Connection Network Cable × 1
- ◆ Mounting Bracket Set × 1

